

|   |   |
|---|---|
| <b>Voltagem:</b><br><b>Operating Voltage:</b><br><b>Tension de fonctionnement:</b><br><b>Tensión de funcionamiento:</b>                               | <b>220/240 Vac, 50/60Hz, 0,84-1.0kW</b> |
| <b>Tipo de motor:</b><br><b>Motor type:</b><br><b>Type de moteur:</b><br><b>Tipo de motor:</b>  | <b>500W, 29000RPM</b>                   |
| <b>Temperatura da saída do ar:</b><br><b>Air output temperature:</b><br><b>Température de l'air chaud:</b><br><b>Temperatura del aire caliente:</b>   | <b>50°C (131°F)</b>                     |
| <b>Velocidade da saída do ar:</b><br><b>Warm air speed output:</b><br><b>Vitesse de l'air chaud:</b><br><b>Velocidad de salida del aire caliente:</b> | <b>90 m/s</b>                           |
| <b>Tempo de secagem:</b><br><b>Drying time:</b><br><b>Temps de séchage:</b><br><b>Tiempo de secado:</b>   | <b>10-15 s</b>                          |
| <b>Isolamento:</b><br><b>Isolation:</b><br><b>Isolément:</b><br><b>Aislamiento:</b>   | <b>CLASS 1</b>                          |

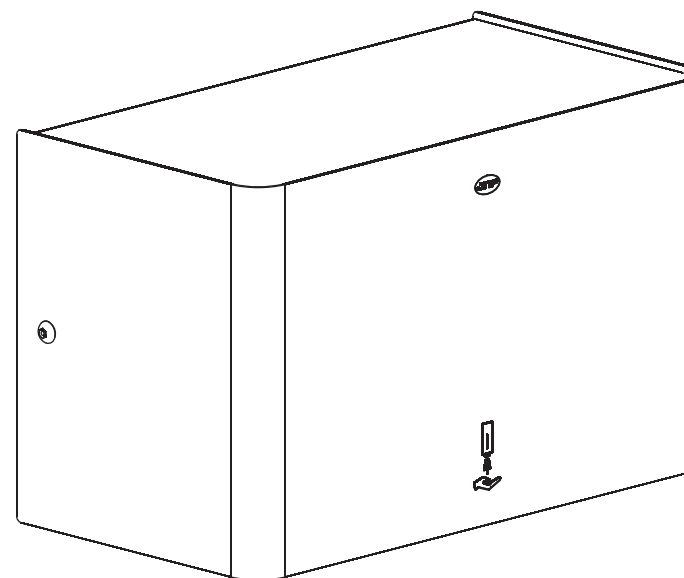

**CIRCUIT DIAGRAM**  
220-240Vac

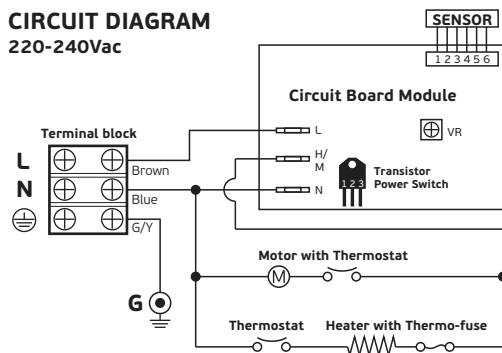

J. Neves & Filhos  
Comércio e Indústria de Ferragens, S.A.

jnf@jnf.pt | www.jnf.pt

Rua das Mimosas, 849/851  
Zona Industrial das Mimosas  
S. Pedro da Cova | Ap. 75  
4424-909 Gondomar - PORTUGAL

## IN.60.566

**SECADOR DE MÃOS AUTOMÁTICO /**  
**AUTOMATIC HAND DRYER /**  
**SÈCHE MAINS ÉLECTRIQUE /**  
**SECADOR DE MANOS AUTOMATICO**

**Esquema de furação/**  
 Drilling template/  
 Gabarit de perçage/  
 Plantilla de perforación/

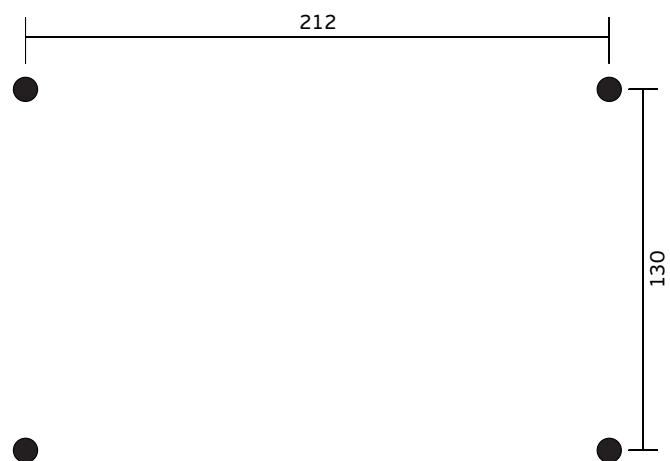

Parede/  
 Wall/  
 Mur/  
 Pared

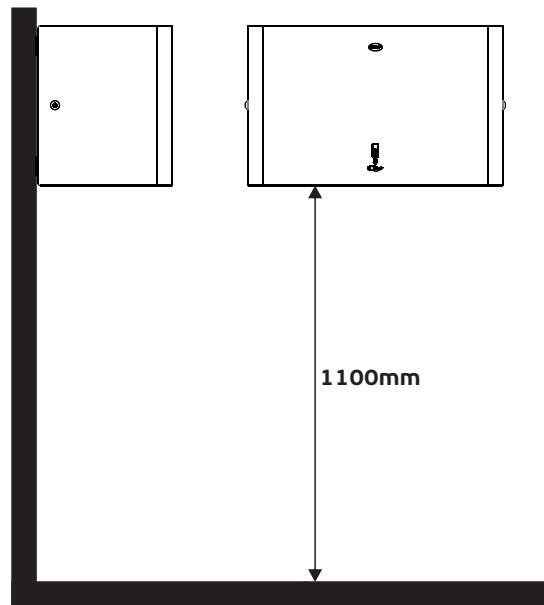

Chão/  
 Floor/  
 Terrain/  
 Suelo

